

# LIFTERS

Lifters are custom designed to raise and lower products, carriers or pallets between conveyor lines at different heights using precise vertical movements. They can be powered by electric, hydraulic and pneumatic systems and utilise either belt or chain-driven mechanisms for operation.

## CONTACT US

☎ +91-8263917801

📍 NKB House, S.No 98,Kothrud,  
Pune 411038

✉ sales@automagindia.in



[www.automagindia.com](http://www.automagindia.com)



# SPECIFICATIONS

- Belt or chain-driven options available for different requirements.
- Electric, pneumatic or hydraulic actuation available.
- Custom designs for different weight capacities and lifting heights.
- Easy maintenance and service access.
- Durable construction reducing the cost of maintenance..

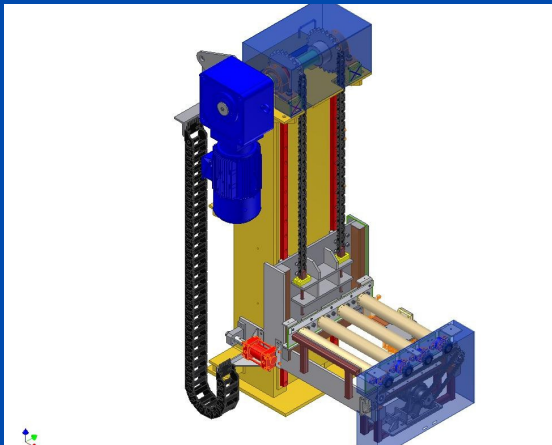

# APPLICATIONS

WE OFFER CUSTOM SOLUTIONS,  
UNMATCHED DURABILITY AND  
END-TO-END SUPPORT.

---

- Elevation change in factories.
- Loading and unloading pallets.
- Order picking in distribution centre.
- Reciprocating conveyors.
- Storage and retrieval systems in high-bay warehouses.

